



# Network Security

## Chapter 2 Basics

### 2.3 Cryptographic Hash Functions

- Motivation
- Cryptographic Hash Functions
  - SHA-1
- Message Authentication Codes (MACs)



## Motivation (1)

- ❑ *Data integrity* is an essential security service
  - ➔ Upon receiving a message  $m$ , we need to detect whether  $m$  has been modified intentionally by an attacker
- ❑ Common practice in data communications: *error detection code* over messages, to identify if errors were introduced during transmission
  - Examples: Parity, Bit-Interleaved Parity, Cyclic Redundancy Check (CRC)
- ➔ Underlying idea of these codes: add redundancy to a message for being able to *detect*, or even *correct* transmission errors
- ➔ The error detection/correction code of choice and its parameters: trade-off between
  - computational overhead
  - increase of message length
  - Probability/characteristics of errors on the transmission medium



## Motivation (2)

- ❑ It is a different (and much harder!) problem to determine if  $m$  has been *modified on purpose!*
- ❑ Consequently, we need to add a *Modification Detection Code* (MDC) that fulfills some additional properties which should make it *computationally infeasible* for an attacker to tamper with messages
- ❑ This property is fulfilled by so-called “cryptographic hash functions”



# Cryptographic Hash Functions: Definition

## □ Definition: **hash function**

- A *hash function* is a function  $h$  which has the following two properties:
  - *Compression*:  $h$  maps an input  $x$  of arbitrary finite bit length to an output  $h(x)$  of fixed bit length  $n$ :

$$h: \{0,1\}^* \rightarrow \{0,1\}^n$$

- *Ease of computation*: Given  $h$  and  $x$  it is *easy* to compute  $h(x)$

## □ Definition: **one-way function**

- A *hash function* is a function  $h$  which has the following property
- for essentially all pre-specified outputs  $y$ , it is *computationally infeasible* to find an  $x$  such that  $h(x) = y$
- e.g. given  $p$  a large prime number and  $g$  a primitive root in  $Z_p^*$

Let 
$$h(x) = g^x \text{ mod } p$$

Then  $h$  is a one-way function



# Cryptographic Hash Functions: Definition

## □ Definition: **cryptographic hash function**

- A *cryptographic hash function*  $h$  is a hash function which additionally satisfies the following properties:

(1)  *$h$  is a one-way function*

This property is also called *(First) Pre-image resistance*

*(“Unbestimmbarkeit von Urbildern”):*

For essentially all pre-specified outputs  $y$ , it is *computationally infeasible* to find an  $x$  such that  $h(x) = y$

(2) *2<sup>nd</sup> pre-image resistance (“Unbestimmbarkeit eines zweiten Urbildes”):*

given  $x$  it is *computationally infeasible* to find any second input  $x'$  with  $x \neq x'$  such that  $h(x) = h(x')$

Note: This property is very important for digital signatures.

(3) *Collision resistance (“Kollisionsfreiheit”):*

it is *computationally infeasible* to find any pair

$(x, x')$  with  $x \neq x'$  such that  $h(x) = h(x')$

(4) *Random oracle property:*

It is computationally infeasible to distinguish  $h(m)$  from random  $n$ -bit value



## General Remarks (1)

- Computational infeasibility
  - In a mathematical sense, the notion of *computational infeasibility* is directly related to complexity theory.
  - It means that no polynomial complexity algorithm for the given problem exists
  - However, cryptographic hash functions, which are actually used in practice, e.g. SHA-1 or MD5, are not directly based on such mathematical problems
- Random output
  - The algorithm for calculating the hash value of a string is deterministic
  - However, the output of a cryptographic hash function should “look” random [Ferg03]
  - In particular, a cryptographic hash function should map two “similar” strings to completely uncorrelated outputs (similar in the sense of a small Hamming distance) [Cos06]
  - In particular, a cryptographic hash function should not be additive
    - If  $x' = x \oplus \Delta$ , then  $H(x')$  should be different from  $H(x) \oplus H(\Delta)$



## General Remarks (2)

- In networking there are codes for error detection.
- Cyclic redundancy checks (CRC)
  - CRC is commonly used in networking environments
  - CRC is based on binary polynomial division with Input / CRC divisor (divisor depends on CRC variant).
  - The remainder of the division is the resulting error detection code.
  - CRC is a fast compression function.
- Why not use CRC?
  - CRC is not a cryptographic hash function
  - CRC does not provide  $2^{\text{nd}}$  pre-image resistance and collision resistance
  - CRC is additive
    - If  $x' = x \oplus \Delta$ , then  $\text{CRC}(x') = \text{CRC}(x) \oplus \text{CRC}(\Delta)$
  - CRC is useful for protecting against noisy channels
  - But not against intentional manipulation



## Application of Cryptographic Hash Functions for Data Integrity

- Cryptographic hash functions are used to detect whether a message has been modified by an attacker
- However, the use of a cryptographic hash function is *not sufficient* to detect whether a message has been modified
- Example: if Alice sends a message  $(x, H(x))$  to Bob, with  $H$  a cryptographic hash function, it holds:
  - The computation of  $H(x)$  is usually based on a well-known algorithm
  - The computation of  $H(x)$  does not include a secret key or anything else bound to the identity of Alice
- ➔ An attacker can modify  $x$  to  $x'$ , calculate  $H(x')$  easily and sends  $(x', H(x'))$  to Bob pretending that this message would be originating from Alice





## Application of Cryptographic Hash Functions for Data Integrity

- Alice needs a different method to prove to Bob that this message has not been changed
  1. Bob might receive the cryptographic hash value via an out-of-band (trusted) channel, e.g. by phone call, or the hash value may be published on a (trusted) web server.
  2. Alice might digitally sign the message and send the signed message to Bob. This requires that Bob knows Alice's public key and is able to verify the signature.
    - In this case, in order to reduce computational overhead, Alice may just sign  $H(x)$  with her private key (instead of  $x$  itself).
    - Due to the 2<sup>nd</sup> pre-image resistance of  $H$ , it is infeasible to an attacker to generate  $x'$  such as  $H(x) = H(x')$ .
    - If an attacker modifies  $x$  to  $x'$ , but does not modify the hash value  $H(x)$ , Bob will detect such a change as the hash value will not be valid:  $H(x) \neq H(x')$
    - If the attacker modifies the hash value from  $H(x)$  to  $H(x')$  as well, then Bob will be able to detect this, since Alice signed  $H(x)$  and not  $H(x')$ . The digital signature will not be valid.



## Application of Cryptographic Hash Functions for Data Integrity

3. In case Alice and Bob share a secret key, Alice can compute a „*Message Authentication Code*“ (MAC) (see later in this chapter) and append it to the message.



## Message Authentication Codes (MACs)

- Definition: **message authentication code**
  - A *message authentication code algorithm* is a family of functions  $h_k$  parameterized by a **secret key  $k$**  with the following properties:
    - *Compression*:  
 $h_k$  maps an input  $x$  of arbitrary finite bitlength to an output  $h_k(x)$  of fixed bitlength, called the MAC
    - *Ease of computation*:  
given  $k$ ,  $x$  and a known function family  $h_k$  the value  $h_k(x)$  is easy to compute
    - *Computation-resistance*:  
for every fixed, allowed, but unknown value of  $k$ , given zero or more text-MAC pairs  $(x_i, h_k(x_i))$  it is computationally infeasible to compute a text-MAC pair  $(x, h_k(x))$  for any new input  $x \neq x_i$
  
- Please note that *computation-resistance* implies the property of *key non-recovery*
  - $k$  can not be recovered from pairs  $(x_i, h_k(x_i))$ ,
  - but computation-resistance can not be deduced from key non-recovery, as the key  $k$  needs not always to be recovered to forge new MACs (as shown in subsequent example)



## A Simple Attack Against an Insecure MAC

- For illustrative purposes, consider the following MAC definition:
  - Input: message  $m = (x_1, x_2, \dots, x_n)$  with  $x_i$  being 64-bit values, and key  $k$
  - Compute  $\Delta(m) := x_1 \oplus x_2 \oplus \dots \oplus x_n$  with  $\oplus$  denoting bitwise exclusive-or
  - Output: MAC  $C_k(m) := E_k(\Delta(m))$  with  $E_k(x)$  denoting DES encryption
- The key length is 56 bit and the MAC length is 64 bit, so we would expect an effort of about  $2^{55}$  operations to obtain the key  $k$  and break the MAC (= being able to forge messages).
- Unfortunately the MAC definition is insecure:
  - Assume an attacker Eve who wants to forge messages exchanged between Alice and Bob obtains a message  $(m, C_k(m))$  which has been “protected” by Alice using the secret key  $k$  shared with Bob
  - Eve can construct a message  $m'$  that yields the same MAC:
    - Let  $y_1, y_2, \dots, y_{n-1}$  be arbitrary 64-bit values
    - Define  $\mathbf{y}_n := y_1 \oplus y_2 \oplus \dots \oplus y_{n-1} \oplus \Delta(m)$
    - This  $\mathbf{y}_n$  allows to construct the new message  $m' := (y_1, y_2, \dots, \mathbf{y}_n)$
    - Therefore,  $C_k(m') = E_k(\Delta(m')) = E_k(y_1 \oplus y_2 \oplus \dots \oplus y_{n-1} \oplus \mathbf{y}_n)$   
 $= E_k(y_1 \oplus y_2 \oplus \dots \oplus y_{n-1} \oplus y_1 \oplus y_2 \oplus \dots \oplus y_{n-1} \oplus \Delta(m))$   
 $= E_k(\Delta(m))$   
 $= C_k(m)$
  - Therefore,  $C_k(m)$  is a valid MAC for  $m'$
  - When Bob receives  $(m', C_k(m))$  from Eve, he will accept it as being originated



# Applications of Cryptographic Hash Functions

- Principal application which led original design:
  - Message integrity:
    - Using public key cryptography:
      - The cryptographic hash value represents a *digital fingerprint*, which can be signed with a private key, e.g. using the RSA or ElGamal algorithms,
      - It is computationally infeasible to construct two messages with the same fingerprint. Therefore, a given signed fingerprint can not be re-used by an attacker
    - Using a shared secret key:
      - A MAC over a message  $m$  directly certifies that the sender of the message possesses the secret key  $k$  and the message could not have been modified without knowledge of that key



## Other Applications which require some Caution (1)

- Pseudo-random number generation
  - The output of a cryptographic hash function is assumed to be uniformly distributed
  - Although this property has not been proven in a mathematical sense for common cryptographic hash functions, such as MD5, SHA-1, it is often used
  - Start with random seed, then hash
    - $b_0 = \text{seed}$
    - $b_{i+1} = H(b_i \mid \text{seed})$
  
- Encryption
  - Remember: Output Feedback Mode (OFB) – encryption performed by generating a pseudo random stream, and performing XOR with plain text
  - Generate a key stream as follow:
    - $k_0 = H(K_{A,B} \mid IV)$
    - $k_{i+1} = H(K_{A,B} \mid k_i)$
  - The plain text is XORed with the key stream to obtain the cipher text.



## Other Applications of Cryptographic Hash Functions

- Authentication with a *challenge-response* mechanism
  - Alice → Bob: random number “ $r_A$ ”
  - Bob → Alice: “ $H(K_{A,B}, r_A)$ ”
  - Based on the assumption that only Alice and Bob know the shared secret  $K_{A,B}$ , Alice can conclude that an attacker would not be able to compute  $H(K_{A,B}, r_A)$ , and therefore that the response is actually from Bob
  - Mutual authentication can be achieved by a 2<sup>nd</sup> exchange in opposite direction
  - This authentication is based on a well-established authentication method called „*challenge-response*“
  - This type of authentication is used, e.g., by HTTP digest authentication
    - It avoids transmitting the transport of the shared key (e.g. password) in clear text
  - Another type of a challenge-response would be, e.g., if Bob signs the challenge “ $r_A$ ” with his private key
  - Note that this kind of authentication does not include negotiation of a session key.
  - Protocols for key negotiation will be discussed in subsequent chapters.



## Other Applications of Cryptographic Hash Functions

- Authentication with One-Time Passwords (OTP):
  - The basic idea of one-time-passwords authentication is to transmit a “password”, that can only be used for one run of an authentication dialogue
  - Initial Setup:
    - The authenticator  $A$  sends a seed value  $r_A$  and the peer entity  $B$  concatenates it with his password and computes a hash value:  
$$PW_N = H^N(r_A, password_B)$$
    - The pair  $(N, PW_N)$  is transmitted to the authenticator and stored at the authenticator
  - Authentication dialogue:
    - $A \rightarrow B: N - 1$
    - $B \rightarrow A: PW_{N-1} := H^{N-1}(r_A, password_B)$
    - $A$  checks if  $H(PW_{N-1}) = PW_N$ , and stores  $(N - 1, PW_{N-1})$  as the new authentication information for  $B$
  - Security: In order to break this scheme, an attacker would have to eavesdrop one  $PW_N$  and compute  $H^{-1}(PW_N)$  which is impractical
  - Note: One-time-passwords must not be confused with one-time-pads





## Other Applications of Cryptographic Hash Functions

- ❑ Cryptographic hash values can also be used for error detection, but they are generally computationally more expensive than simple error detection codes such as CRC



## Overview of Commonly Used Cryptographic Hash Functions and Message Authentication Codes

- Cryptographic Hash Functions:
  - Message Digest 5 (MD5):
    - Invented by R. Rivest
    - Successor to MD4
    - Considered to be broken.
  - Secure Hash Algorithm 1 (SHA-1):
    - Invented by the National Security Agency (NSA)
    - The design was inspired by MD4
- Message Authentication Codes:
  - DES-CBC-MAC, AES-CBC-MAC
    - Uses the Data Encryption Standard DES (or AES) in Cipher Block Chaining mode  
(Encryption: XOR plain text with cipher text of previous block, then encrypt)
    - In general, the CBC-MAC construction can be used with any block cipher
  - MACs constructed from cryptographic hash functions:
    - Example HMAC:  $H(K, p_1, H(K, p_2, m))$ , RFC 2104, details later
    - This very common approach raises some cryptographic concern as it makes some implicit but unverified assumptions about the properties of the hash function



## Common Structure of Cryptographic Hash Functions (1)

- Like most of today's block ciphers follow the general structure of a Feistel network, most cryptographic hash functions in use today follow a common structure:
  - Let  $y$  be an arbitrary message. Usually, the length of the message is appended to the message and padded to a multiple of some block size  $b$ . Let  $(y_0, y_1, \dots, y_{L-1})$  denote the resulting message consisting of  $L$  blocks of size  $b$
  - The general structure is as depicted below:

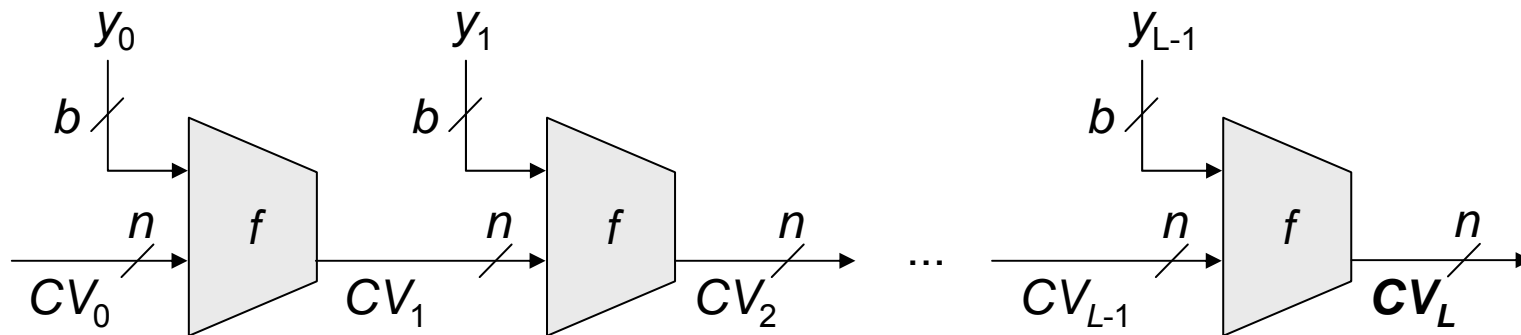

- $CV$  is a *chaining value*, with  $CV_0 := IV$  and  $H(y) := CV_L$
- $f$  is a specific compression function which compresses  $(n + b)$  bit to  $n$  bit



## Common Structure of Cryptographic Hash Functions (2)

- The hash function  $H$  can be summarized as follows:

$$CV_0 = IV \quad = \text{initial } n\text{-bit value}$$

$$CV_i = f(CV_{i-1}, y_{i-1}) \quad 1 \leq i \leq L$$

$$H(y) = CV_L$$

- It has been shown [Mer89a] that if the compression function  $f$  is collision resistant, then the resulting iterated hash function  $H$  is also collision resistant
- Cryptanalysis of cryptographic hash functions thus concentrates on the internal structure of the function  $f$  and finding efficient techniques to produce collisions for a single execution of  $f$
- Primarily motivated by birthday attacks, a common minimum suggestion for  $n$ , the bit length of the hash value, is 160 bit, as this implies an effort of order  $2^{80}$  to attack which is considered infeasible today



# The Secure Hash Algorithm SHA-1 (1)

- Also SHA-1 follows the common structure as described above:
  - SHA-1 works on 512-bit blocks and produces a 160-bit hash value
  - Initialization
    - The data is padded, a length field is added and the resulting message is processed as blocks of length 512 bit
    - The chaining value is structured as five 32-bit registers A, B, C, D, E
    - Initialization:  $A = 0x\ 67\ 45\ 23\ 01$   $B = 0x\ EF\ CD\ AB\ 89$   
 $C = 0x\ 98\ BA\ DC\ FE$   $D = 0x\ 10\ 32\ 54\ 76$   
 $E = 0x\ C3\ D2\ E1\ F0$
    - The values are stored in big-endian format
  - Each block  $y_i$  of the message is processed together with  $CV_i$  in a module realizing the compression function  $f$  in four rounds of 20 steps each.
    - The rounds have a similar structure but each round uses a different primitive logical function  $f_1, f_2, f_3, f_4$
    - Each step makes use of a fixed additive constant  $K_t$ , which remains unchanged during one round
  - The text block  $y_i$  which consists of 16 32-bits words is „stretched“ with a recurrent linear function in order to make 80 32-bits out of it, which are required for the 80 steps:
    - $t \in \{0, \dots, 15\} \Rightarrow W_t := y_i[t]$
    - $t \in \{16, \dots, 79\} \Rightarrow W_t := CLS_1(W_{t-16} \oplus W_{t-14} \oplus W_{t-8} \oplus W_{t-3})$



## The Secure Hash Algorithm SHA-1 (2) - One Step

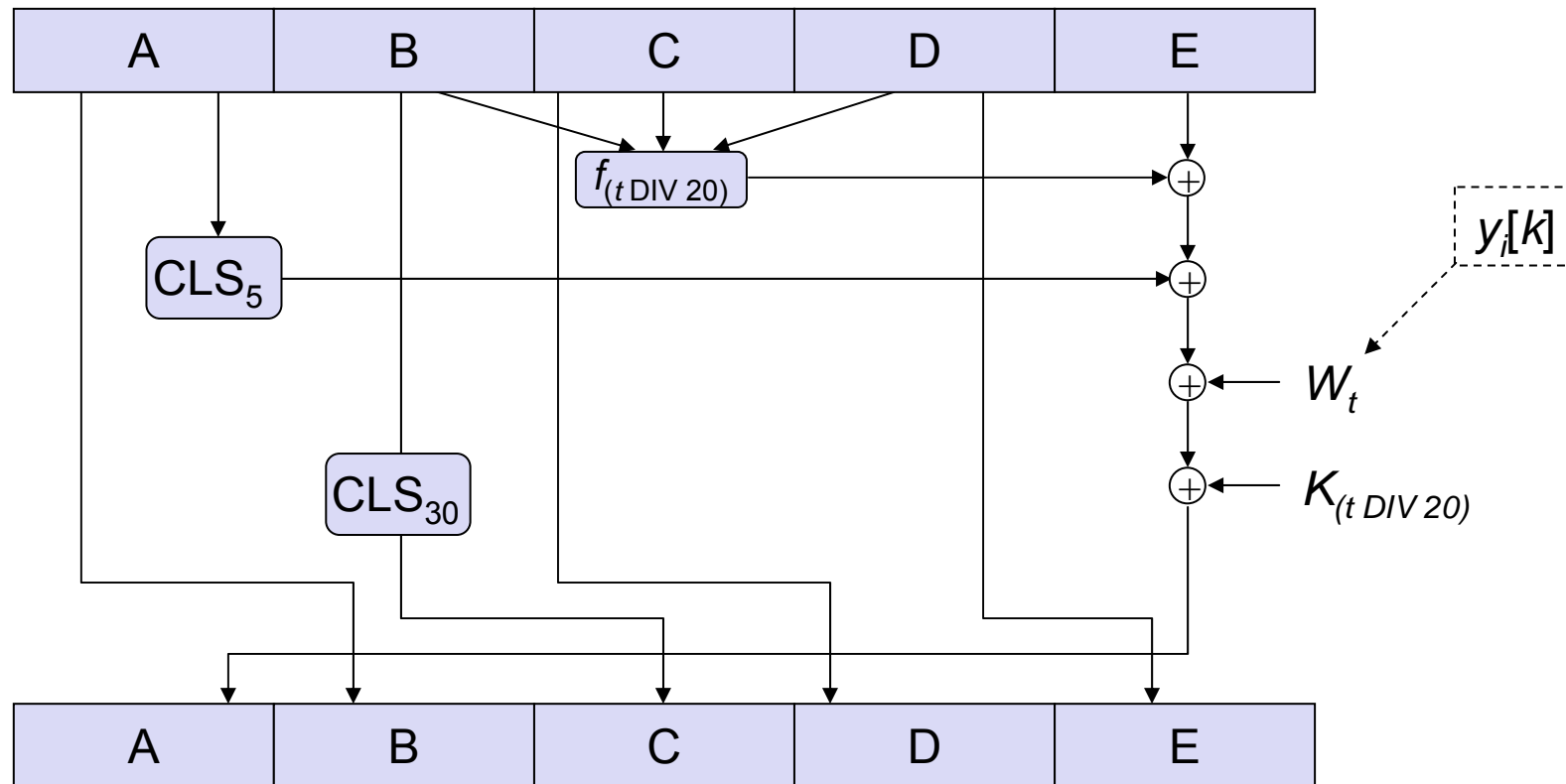

- After step 79 each register A, B, C, D, E is added modulo  $2^{32}$  with the value of the corresponding register before step 0 to compute  $CV_{i+1}$



## The Secure Hash Algorithm SHA-1 (3)

- ❑ The SHA-1 value over a message is the content of the chaining value CV after processing the final message block
- ❑ Security of SHA-1:
  - As SHA-1 produces a hash value of length 160 bit, it offers better security than MD5 with its 128 bits.
  - In February 2005, 3 Chinese Scientists published a paper where they break SHA-1 collision resistance within  $2^{69}$  steps, which is much less than expected from a cryptographic hash function with an output of 160 bits ( $2^{80}$ ).
  - Meanwhile down to  $2^{52}$  steps (EuroCrypt 2009 Rump Session).
  - Up to now, no attacks on the pre-image resistance of SHA-1 have been published.



## Competitions for a new hash standard SHA-3

- ❑ MD5 is considered to be broken and SHA-1 is under heavy attack.
- ❑ Performance of SHA-1 worse than performance of upto date symmetric ciphers like AES or Twofish.
- ➔ NIST startet a competition for a new hash function standard that will be called SHA-3.
  
- ❑ NIST SHA-3 competition
  - Competition announced in 2007.
  - Round1: 51 candidates accepted, 13 rejected. (December 2008)
  - Round2: 14 candidates survived. (July 2009)
  - Final decision expected in 2012.
  - SHA-3 is required to be
    - Fast
    - Secure





## Attacks Based on the Birthday Phenomenon (1)

- ❑ Attack against collision resistance of cryptographic hash functions
- ❑ The Birthday Phenomenon:
  - How many people need to be in a room such that the possibility that there are at least two people with the same birthday is greater than 0.5?
  - For simplicity, we don't care about February, 29, and assume that each birthday is equally likely
- ❑ Define  $P(n, k) := \Pr[\text{at least one duplicate in } k \text{ items, with each item able to take one of } n \text{ equally likely values between } 1 \text{ and } n]$
- ❑ Define  $Q(n, k) := \Pr[\text{no duplicate in } k \text{ items, each item between } 1 \text{ and } n]$ 
  - $P(n, k) = 1 - Q(n, k)$
  - We are able to choose the first item from  $n$  possible values, the second item from  $n - 1$  possible values, etc.
  - Hence, the number of different ways to choose  $k$  items out of  $n$  values with no duplicates is:  $N = n \times (n - 1) \times \dots \times (n - k + 1) = n! / (n - k)!$
  - The number of different ways to choose  $k$  items out of  $n$  values, with or without duplicates is:  $n^k$
  - So,  $Q(n, k) = N / n^k = n! / ((n - k)! \times n^k)$



## Attacks Based on the Birthday Phenomenon (2)

- $P(n, k) := \Pr[\text{at least one duplicate in } k \text{ items, with each item able to take one of } n \text{ equally likely values between } 1 \text{ and } n]$

- We have: 
$$\begin{aligned} P(n, k) &= 1 - Q(n, k) = 1 - \frac{n!}{(n-k)! \times n^k} \\ &= 1 - \frac{n \times (n-1) \times \dots \times (n-k+1)}{n^k} \\ &= 1 - \left[ \frac{n-1}{n} \times \frac{n-2}{n} \times \dots \times \frac{n-k+1}{n} \right] \\ &= 1 - \left[ \left(1 - \frac{1}{n}\right) \times \left(1 - \frac{2}{n}\right) \times \dots \times \left(1 - \frac{k-1}{n}\right) \right] \end{aligned}$$

- We will use the following inequality:  $(1 - x) \leq e^{-x}$  for all  $x \geq 0$

- So: 
$$\begin{aligned} P(n, k) &> 1 - \left[ \left(e^{-1/n}\right) \times \left(e^{-2/n}\right) \times \dots \times \left(e^{-(k-1)/n}\right) \right] \\ &= 1 - e^{-\left[\left(1/n\right) + \left(2/n\right) + \dots + \left(k-1/n\right)\right]} \\ &= 1 - e^{-k \times (k-1) / 2n} \end{aligned}$$



## Attacks Based on the Birthday Phenomenon (3)

- In the last step, we used the equality:  $1 + 2 + \dots + (k - 1) = (k^2 - k) / 2$ 
  - Exercise: proof the above equality by induction
- Let's go back to our original question: how many people  $k$  have to be in one room such that there are at least two people with the same birthday (out of  $n = 365$  possible) with probability  $\geq 0,5$ ?

- So, we want to solve: 
$$\frac{1}{2} = 1 - e^{-k \times (k-1) / 2n}$$

$$\Leftrightarrow 2 = e^{k \times (k-1) / 2n}$$

$$\Leftrightarrow \ln(2) = \frac{k \times (k-1)}{2n}$$

- For large  $k$  we can approximate  $k \times (k - 1)$  by  $k^2$ , and we get:

$$k = \sqrt{2 \ln(2)n} \approx 1.18\sqrt{n}$$

- For  $n = 365$ , we get  $k = 22.54$  which is quite close to the correct answer 23



## Attacks Based on the Birthday Phenomenon (4)

- What does this have to do with cryptographic hash functions?
- We have shown, that if there are  $n$  possible different values, the number  $k$  of values one needs to randomly choose in order to obtain a pair of identical values with probability  $\geq 0.5$ , is in the order of  $\sqrt{n}$
- Now, consider the “*Yuval’s square root attack*” [Yuv79a]:
  - Eve wants Alice to sign a message  $m1$  which Alice normally never would sign. Eve knows that Alice uses the function  $H$  to compute a cryptographic hash value of  $m$ . The hash value has length  $r$  bit before she signs it with her private key yielding her digital signature
  - First, Eve produces her message  $m1$ . If she would now compute  $H(m1)$  and then try to find a second harmless message  $m2$  which leads to the same hash value her search effort in the average case would be on the order of  $2^{(r-1)}$
  - Instead she takes any harmless message  $m2$  and starts producing variations  $m1'$  and  $m2'$  of the two messages, e.g. by adding <space> <backspace> combinations or varying with semantically identical words



## Attacks Based on the Birthday Phenomenon (5)

- ❑ As we learned from the birthday phenomenon, Eve will just have to produce about  $\sqrt{2^r} = 2^{r/2}$  variations of each of the two messages such that the probability that she obtains two messages  $m1'$  and  $m2'$  with the same hash value is at least 0.5
- ❑ As she has to store the messages together with their hash values in order to find a match, the memory requirement of her attack is on the order of  $2^{r/2}$  and its computation time requirement is on the same order
- ❑ After she has found  $m1'$  and  $m2'$  with  $H(m1') = H(m2')$  she asks Alice to sign  $m2'$ . Eve can then take this signature and claim that Alice signed  $m1'$



## Attacks Based on the Birthday Phenomenon (6)

- Attacks following this method are called *birthday attacks*
- Consider now, that Alice uses RSA with keys of length 2048 bit and a cryptographic hash function which produces hash values of length 96 bit.
  - Eves average effort to produce two messages  $m1'$  and  $m2'$  as described above is on the order of  $2^{48}$ , which is feasible today. Breaking RSA keys of length 2048 bit is far out of reach with today's algorithms and technology



## Cipher Block Chaining Message Authentication Codes (1)

- A CBC-MAC is computed by encrypting a message in CBC Mode and taking the last ciphertext block or a part of it as the MAC:

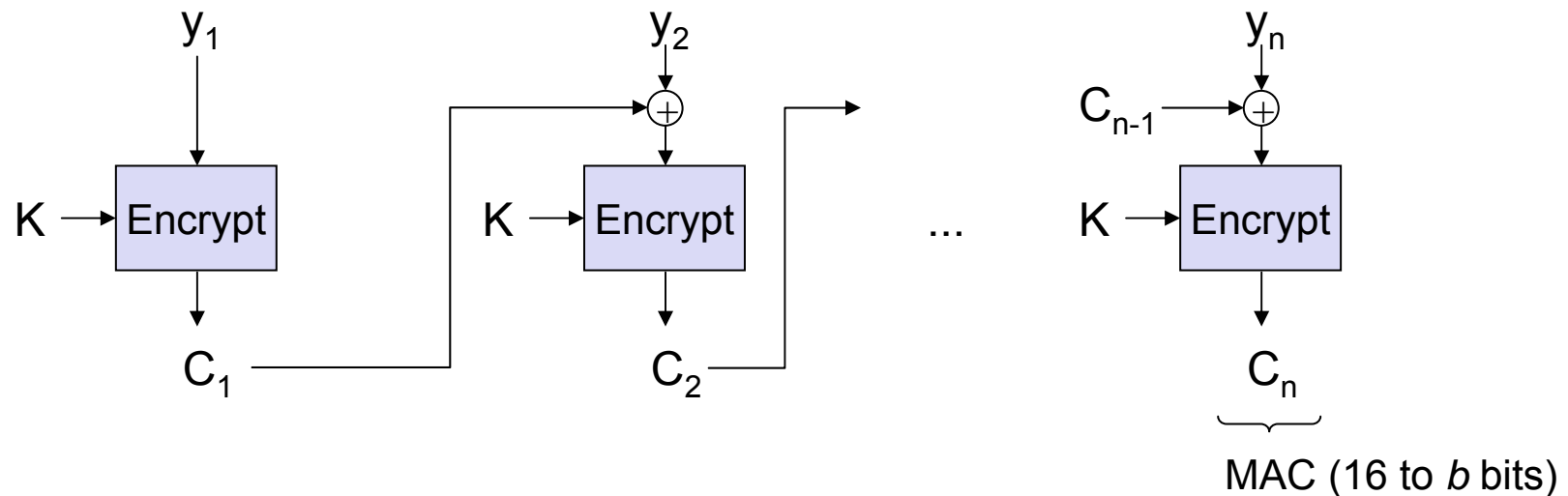

- This MAC needs not to be signed any further, as it has already been produced using a shared secret  $K$ 
  - However, it is not possible to say who exactly has created a MAC, as everybody (sender, receiver) who knows the secret key  $K$  can do so
- This scheme works with any block cipher (DES, AES, ...)



## Cipher Block Chaining Message Authentication Codes (2)

- CBC-MAC security
  - CBC-MAC must NOT be used with the same key as for the encryption
  - In particular, if CBC mode is used for encryption, and CBC-MAC for integrity with the same key, the MAC will be equal to the last cipher text block
  - Otherwise, AES-CBC-MAC is considered to be secure
  - It is used, e.g., for IEEE 802.11 (WLAN) WPA2
- CBC-MAC performance
  - Older symmetric block ciphers (such as DES) require more computing effort than dedicated cryptographic hash functions, e.g. MD5, SHA-1 therefore, these schemes are considered to be slower.
  - However, newer symmetric block ciphers (AES) is faster than conventional cryptographic hash functions.
  - Therefore, AES-CBC-MAC is becoming popular.





## Constructing a MAC from a Cryptographic Hash Functions (1)

- ❑ Reasons for constructing MACs from cryptographic hash functions :
  - Cryptographic hash functions generally execute faster than symmetric block ciphers (Note: with AES this isn't much of a problem today)
  - There are no export restrictions to cryptographic hash functions
- ❑ Basic idea: “mix” a secret key  $K$  with the input and compute a hash value
- ❑ The assumption that an attacker needs to know  $K$  to produce a valid MAC nevertheless raises some cryptographic concern:
  - The construction  $H(K | m)$  is not secure
  - The construction  $H(m, K)$  is not secure
  - The construction  $H(K, p, m, K)$  with  $p$  denoting an additional padding field does not offer sufficient security



## Constructing a MAC from a Cryptographic Hash Functions (2)

- The construction  $H(K | m | K)$ , called prefix-suffix mode, has been used for a while.
  - See for example [RFC 1828]
  - It has been also used in earlier implementations of the Secure Socket Layer (SSL) protocol (until SSL 3.0)
  - However, it is now considered vulnerable to attack by the cryptographic community.

- The most used construction is:

$$H(K \oplus opad | H(K \oplus ipad | m))$$

- The length of the key  $K$  is first extended to the block length required for the input of the hash function  $H$  by appending zero bytes.
- Then it is xor'ed respectively with two constants  $opad$  and  $ipad$
- The hash function is applied twice in a nested way.
- Currently no attacks have been discovered on this MAC function. (see note 9.67 in [Men97a])
- It is standardized in RFC 2104 [Kra97a] and is called **HMAC**



## Additional References

(Beyond the scope of examination)

- [Cos06] B. Coskun, N. Memon, "Confusion/Diffusion Capabilities of Some Robust Hash Functions", CISS 2006: Conference on Information Sciences and Systems, March 22-24, 2006, Princeton, NJ
- [Kra97a] H. Krawczyk, M. Bellare, R. Canetti. *HMAC: Keyed-Hashing for Message Authentication*. Internet RFC 2104, February 1997.
- [Mer89a] R. Merkle. *One Way Hash Functions and DES*. Proceedings of Crypto '89, Springer, 1989.
- [Ferg03] Niels Ferguson, Bruce Schneier, „Practical Cryptography“, John Wiley & Sons, 2003
- [PSMD5] Peter Selinger, <http://www.mscs.dal.ca/~selinger/md5collision/>
- [RFC1828] P. Metzger, „IP Authentication using Keyed MD5“, IETF RFC 1828, August 1995
- [Riv92a] R. L. Rivest. *The MD5 Message Digest Algorithm*. Internet RFC 1321, April 1992.
- [Rob96a] M. Robshaw. *On Recent Results for MD2, MD4 and MD5*. RSA Laboratories' Bulletin, No. 4, November 1996.
- [Yiqun05] Xiaoyun Wang, Yiqun Lisa Yin, and Hongbo Yu, "Collision Search Attacks on SHA1", February 2005, <<http://theory.csail.mit.edu/~yiqun/shanote.pdf>>
- [Yuv79a] G. Yuval. *How to Swindle Rabin*. Cryptologia, July 1979.